

**RECIRCULATING DOCUMENT
HANDLER
(Machine Code: A378)**

1. SPECIFICATIONS

Original Size:	Max A3, 11" x 17" Min A5 lengthwise, 5 1/2" x 8 1/2" (No A5 Sideways, 8 1/2 x 5 1/2)
Original Weight:	52~104 g/m ² (14~28 lb) (ARF) 52~128 g/m ² (14~34 lb) (ADF)
Original Feed Mode:	Automatic Feed (ADF) Automatic Recycle Feed (ARF)
Original Capacity:	Max 50 sheets (A4, 8 1/2" x 11")
Original Separation:	Feed and Friction Belts system
Original Transport:	One flat belt
Original Stop System:	DC servo motor control system
Copying Speed:	Continuous copy 55 cpm (A4S, 11" x 8 1/2", 1st feed station) Single copy 55 cpm (A4S, 11" x 8 1/2", 1st feed station)
Number of Cycles per Document:	Max 30 times
Power Source:	24V (from copier), 5 A
Power Consumption:	70W
Dimensions: (W x D x H)	645 x 516 x 132 millimeters (25.4 x 20.4 x 5.2 inches)
Weight:	Approximately 18 kg (39.7 lb)

2. MECHANICAL COMPONENT LAYOUT

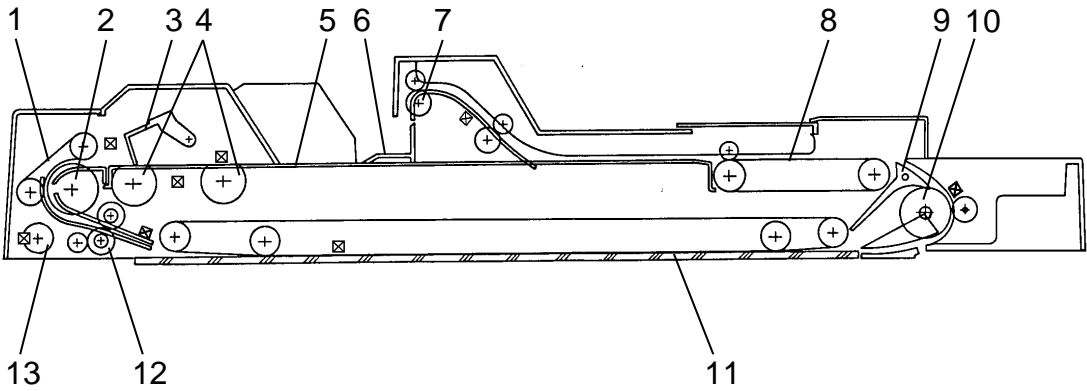

1. Friction Belts

2. Feed Roller

3. Original Gate

4. Pick-up Rollers

5. Original Stacker

6. Push-plate

7. Feed-out Rollers

8. Exit Relay Belts

9. Inverter Pawls

10. Inverter Roller

11. Transport Belt

12. Pull-out Roller

13. Pulse Generator

3. ELECTRICAL COMPONENT DESCRIPTIONS

Symbol	Name	Function	Index No.
Motors			
M1	Feed-in Motor	Drives the feed-in system (pick-up rollers, feed roller, and pull-out roller). (dc servo)	3
M2	Transport Belt Motor	Drives the transport belt. (dc servo)	4
M3	Inverter Motor	Drives the inverter roller and the exit relay belts.	9
M4	Feed-out Motor	Drives the feed-out unit.	15
M5	Friction Belt Motor	Drives the friction belts	21
Solenoids			
SOL1	Original Gate Solenoid	Energizes to open the original gate.	22
SOL2	Inverter Solenoid	Energizes to invert the original when copying a two-sided original.	8
SOL3	Push Plate Solenoid	Energizes to push the stack of originals to the feed-in section.	14
Switches			
SW1	Lift Switch	Informs the copier CPU when the RDH is lifted and also serves as the jam reset switch for the RDH.	7
SW2	Feed-in Unit Safety Switch	Detects if the feed-in unit is set correctly.	23
SW3	Feed-out Unit Safety Switch	Detects if the feed-out unit is set correctly.	10

Symbol	Name	Function	Index No.
Sensors			
S1	Original Set Sensor	Informs the copier CPU that originals have been placed and causes the Insert Original indicator to go out.	17
S2	Recycle Sensor	Informs the CPU when the top original is fed from the original stacker.	19
S3	Registration Sensor	Sets original stop timing and measures the original's length.	17
S4	Original Width Sensor	Determines the width of the original.	20
S5	Pulse Generator Sensor	Generates the pulses used to measure the original's length.	1
S6	Inverter Sensor	Sets original stop timing when in auto reverse mode.	11
S7	Feed-out Sensor	Checks for original misfeeds.	13
S8	One Turn Sensor	Informs the CPU when the pick-up roller turns one rotation.	6
S9	RDH Position Sensor	Informs the CPU when the RDH is being closed so that APS sensor can begin checking the original size.	16
Magnetic Clutch			+
CL1	Feed-in clutch	Energizes to rotate the feed roller.	2
Printed Circuit Boards			
PCB1	RDH Main PCB	Controls all RDH functions.	12
PCB2	Indicator Panel PCB	Contains indicators for the operator.	5

4. BASIC OPERATION

4.1 ONE-SIDED ORIGINAL FEED

When an original is placed in the RDH, the Set Original indicator goes out and the RDH informs the copier that originals have been set.

When the Start key is pressed, the copier CPU sends the feed-in signal to the RDH. On receipt of this signal, the gate solenoid turns on, opening the original gate. At the same time the push-plate solenoid and the feed-in motor turn on. The push-plate and pick-up rollers move the entire stack of originals to the feed position.

After that, the feed-in motor starts turning again. The bottom original is fed in by the feed roller and the friction belts and delivered to the exposure glass by the transport belt.

After a very short period, the second original is also fed in until its leading edge reaches the registration sensor. This is in preparation for the next copy cycle.

When the scanner reaches the return position, the copier CPU sends the feed-out and the feed-in signals to the RDH in order to feed in the second original. If the first original is A4/Letter size (sideways feed) or smaller, it is not fed out as the next original is transported to the exposure glass. It is just moved to the right side of the exposure glass. After completing the second scan, the third original is fed in and **the first original** is fed out from the unit. This continues until all originals have been copied.

The originals are stacked on the original table where they wait for the next copy cycle.

4.2 TWO-SIDED ORIGINAL FEED

Unlike one-sided original feed, the back-side of the original must be copied first to keep the originals and copies in correct order.

During original feed-in, the sequence is the same as for one-sided feed; however, the RDH CPU also energizes the feed-out motor and the inverter solenoid a short time after the original's leading edge has passed the RDH registration sensor. The transport belt motor continues to feed the original until the inverter mechanism inverts the original for the back-side copying. Then, the transport belt motor reverses to feed the original towards the scale, and stops the original at the correct position on the exposure glass.

When the scanner reaches the return position, the copier CPU sends the feed-out signal to the RDH CPU. The RDH then inverts the original in the same way as for back-side copying.

5. FEED-IN DRIVE MECHANISM

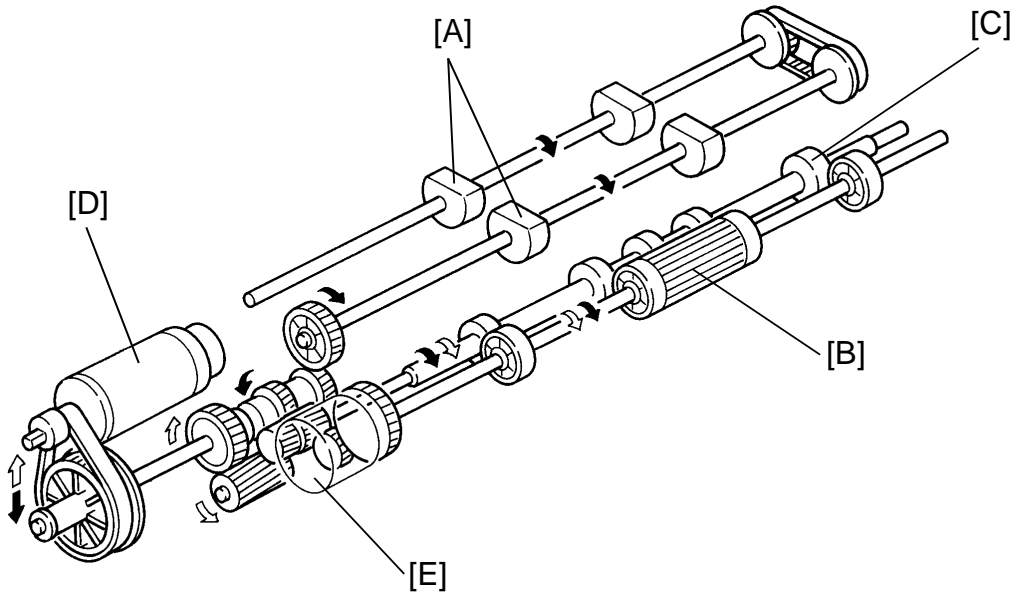

The pick-up rollers [A], feed roller [B], and the pull-out rollers [C] are driven by the feed-in motor [D] through the timing belt, the gears and the feed-in clutch [E].

-Basic Operation-

The feed-in motor is a reversible dc motor. When the feed-in motor rotates forward (counterclockwise), all the rollers turn in the original feed direction. (The feed roller can rotate only when the feed-in clutch is on.)

When the feed-in motor reverses, the pick-up rollers stop. However, the feed roller and the pull-out rollers continue turning in the same direction.

Roller(s)	Feed-in Motor	
	Forward	Reverse
Pick-up	On	Off
Feed	On/Off	On/Off
Pull-out	On	On

(* Only when the feed-in clutch turns on, the feed roller rotates.)

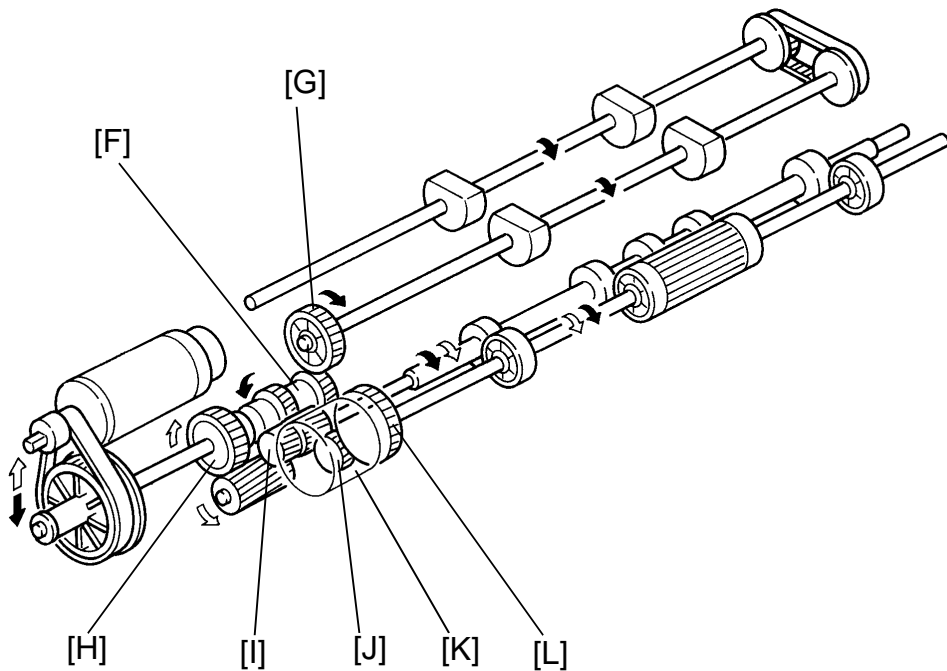

When the Start Key is pressed, the feed-in motor starts turning counterclockwise. Drive is transferred to the pick-up rollers through gears [E] and [G] and to the feed-in clutch through gears [H] and [J]. The timing of the feed roller rotation is controlled by the feed-in clutch [K].

Next, the feed-in motor reverses (clockwise). The pick-up rollers stop turning due to the one-way bearing inside the gears [F] and [H]. However, the feed roller continues turning in the **same direction** through gears [H], [I], [J], [L], and the feed-in clutch.

Since the pull-out roller is installed on the shaft of gear [H], the pull-out roller always turns in the original feed direction whenever the feed-in motor is turned on.

6. ONE-TURN SENSOR

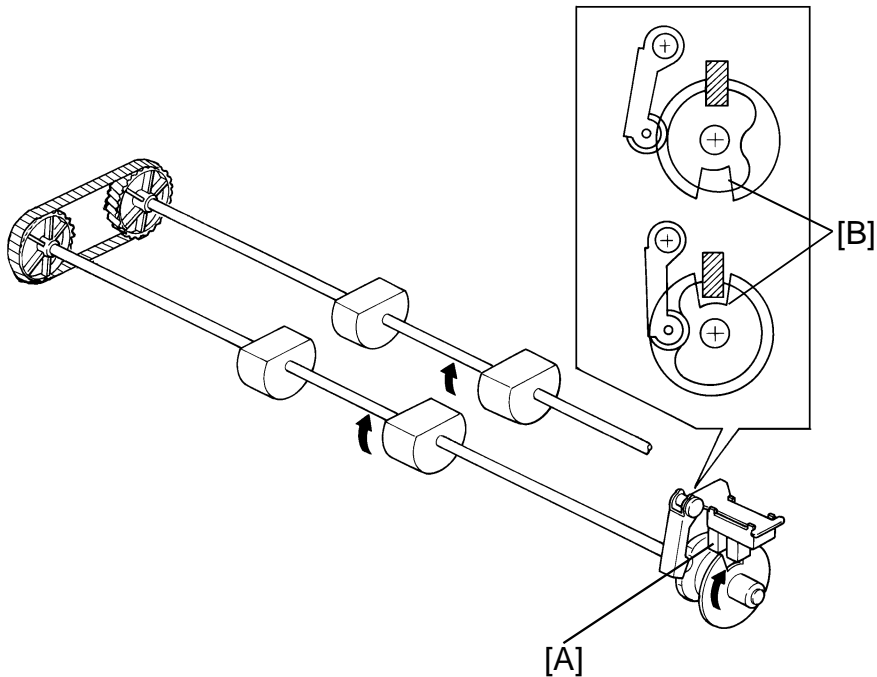

The one-turn sensor [A] is located at the rear end of the pick-up roller shaft. It counts the rotations of the pick-up rollers.

Every 360°, the notch [B] in the one-turn disk returns to the one-turn sensor and the sensor turns on.

When feeding an original, the RDH CPU monitors the rotation of the pick-up rollers through this sensor. It always stops the rollers with their flat surfaces facing up.

7. ORIGINAL SETTING FOR RECYCLE

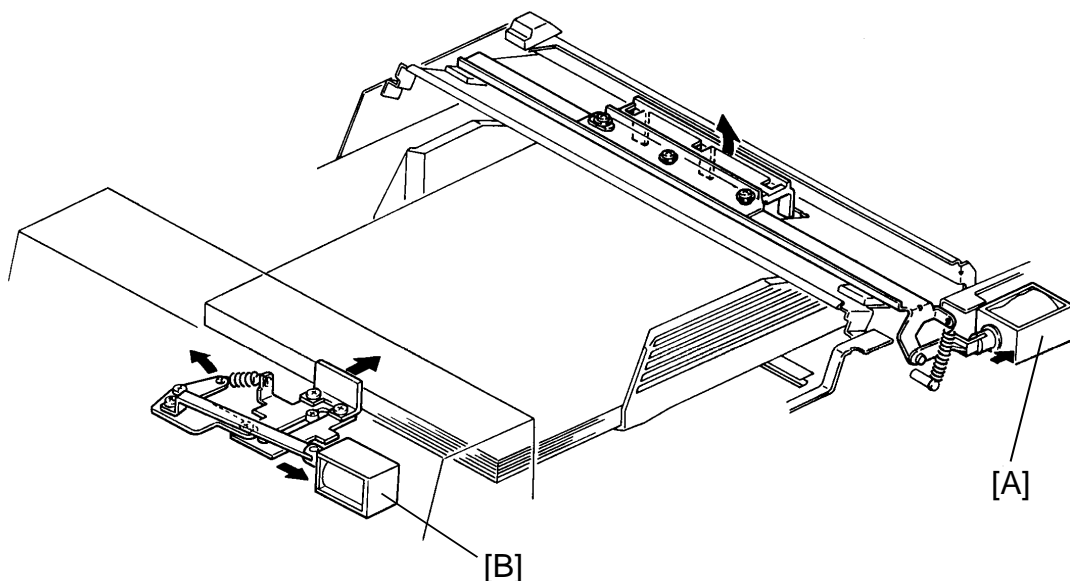

When the Start Key is pressed, the original gate solenoid [A] is energized to open the original gate. At the same time, the push plate solenoid [B] is energized and the pick-up rollers start turning. The pick-up rollers and the push plate move the entire stack of originals to the feed-in section.

At this time, the originals turn the recycle sensor on. After that, the originals are fed one by one from the bottom of the stack. The recycle sensor stays on until the last original is fed.

The copied originals are fed out from the feed-out unit onto the original stacker where they wait for the next cycle.

When the last original is fed in from the feed-in section, the recycle sensor turns off. This informs the RDH CPU that all the originals have been fed in for the first set of copies.

Soon after the last original passes the recycle sensor, the original gate is opened again and the push plate and the pick-up rollers move the stack of originals to the feed-in section for the second cycle. This is the pre-stacking cycle. However, the last few originals of the first cycle have not fed out yet, at this moment. In order to set them on the pre-stacked originals, the original gate, and the push plate are energized again after the last original is fed out.

This recycle system increases the total copy productivity to 55 cpm for A4, or 8_{1/2}"x11" originals (sideways feed and 100% reproduction ratio).

8. ORIGINAL FEED-IN

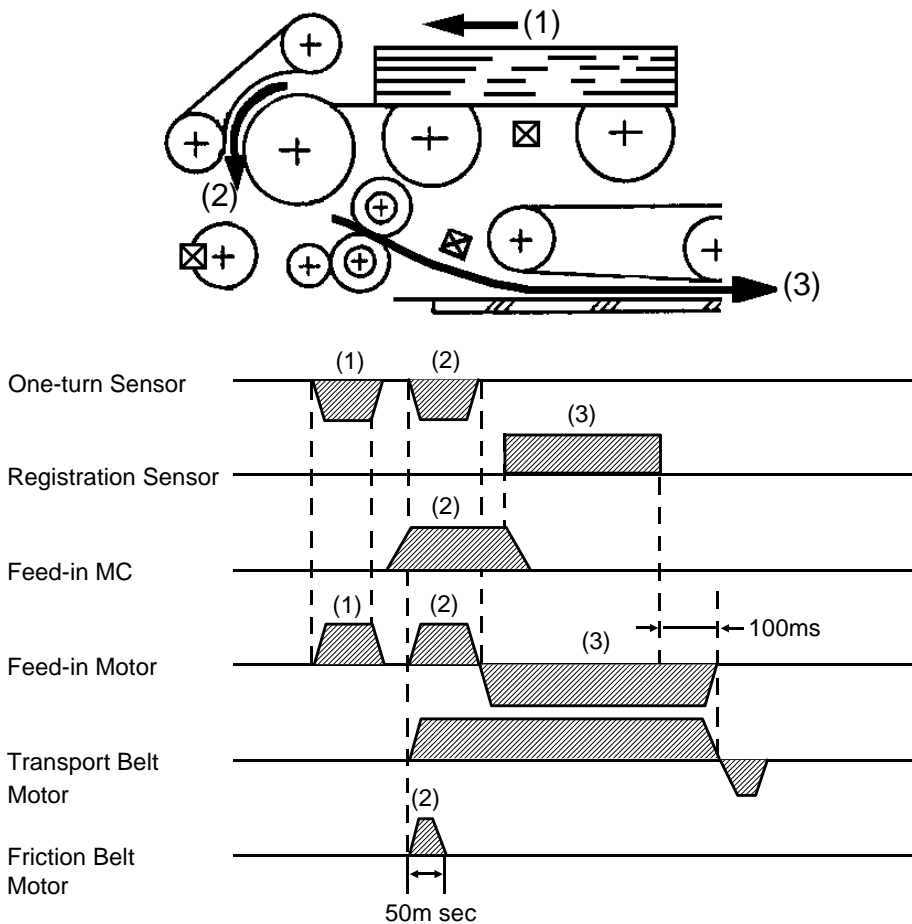

Soon after the entire stack of the originals are moved to the feed-in position (1), the feed-in clutch and the friction belt motor turn on. The friction belt motor rotates for 50 milliseconds counter to the direction of the feed roller rotation to ensure the separation of the bottom original (2).

When the leading edge of the original reaches the registration sensor, the feed-in clutch turns off and the feed-in motor reverses (3). From this time onward, the pull-out rollers take over and feed the original to the transport section.

The registration sensor also serves to measure the original length. The RDH CPU determines the original size by counting how many pulses it receives while the original passes the sensor.

The original width is checked by the original width sensor, which is located next to the registration sensor.

The original stop position is determined by pulse count from the time the original trailing edge passes the registration sensor.

9. ORIGINAL INVERSION MECHANISM

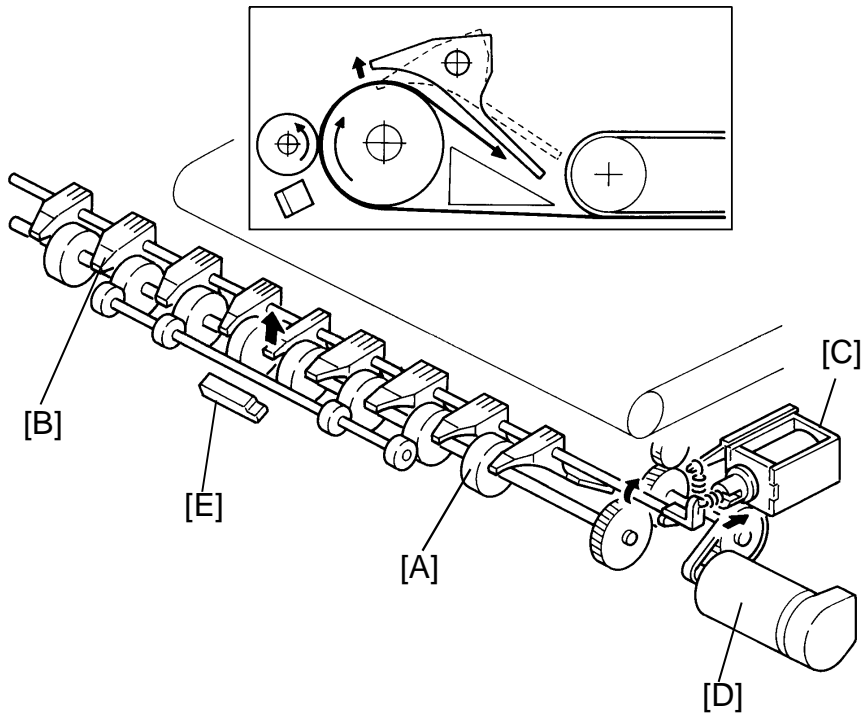

Two sided originals are inverted by the inverter rollers [A] and the inverter pawls [B]. When the inverter solenoid [C] is energized, the inverter pawls are opened and the original is inverted.

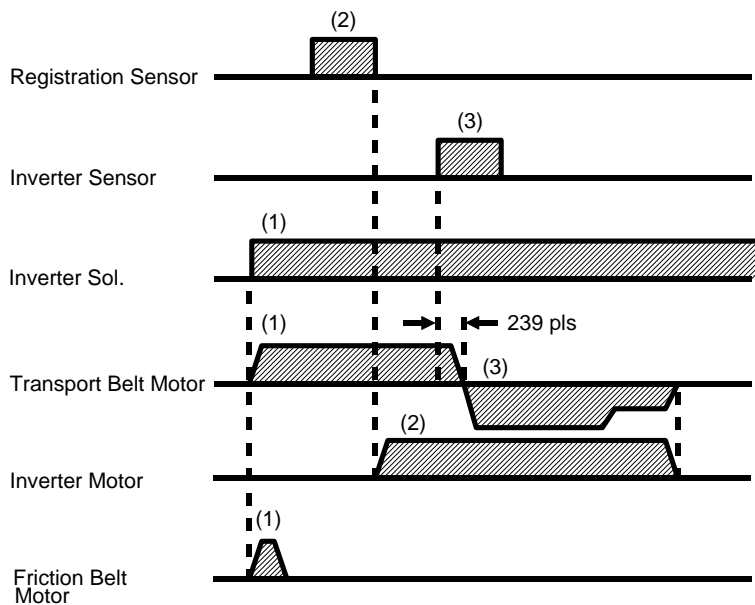

When the Start key is pressed, the two sided original is fed into the transport section. The inverter solenoid is energized at the same time as the transport belt motor and the friction belt motor turns on. (1)

When the trailing edge of the original passes the registration sensor, the inverter motor [D] starts turning. (2)

The original passes over the exposure glass and goes into the inverter section. Since the inverter pawls are already open at that time, the original is inverted and directed back to the transport belt section. The transport belt motor reverses 239 pulses after the leading edge of the original passes the inverter sensor [E]. (3)

The transport belt then moves the original to the original scale.

The back side of the original is copied first.

After the back side is exposed, the transport belt motor and the inverter solenoid turn on again. The original is moved to the inverter rollers and inverted, and then moved back to the scale.

After the front side is exposed, the original is fed out of the RDH unit.

10. ORIGINAL FEED-OUT MECHANISM

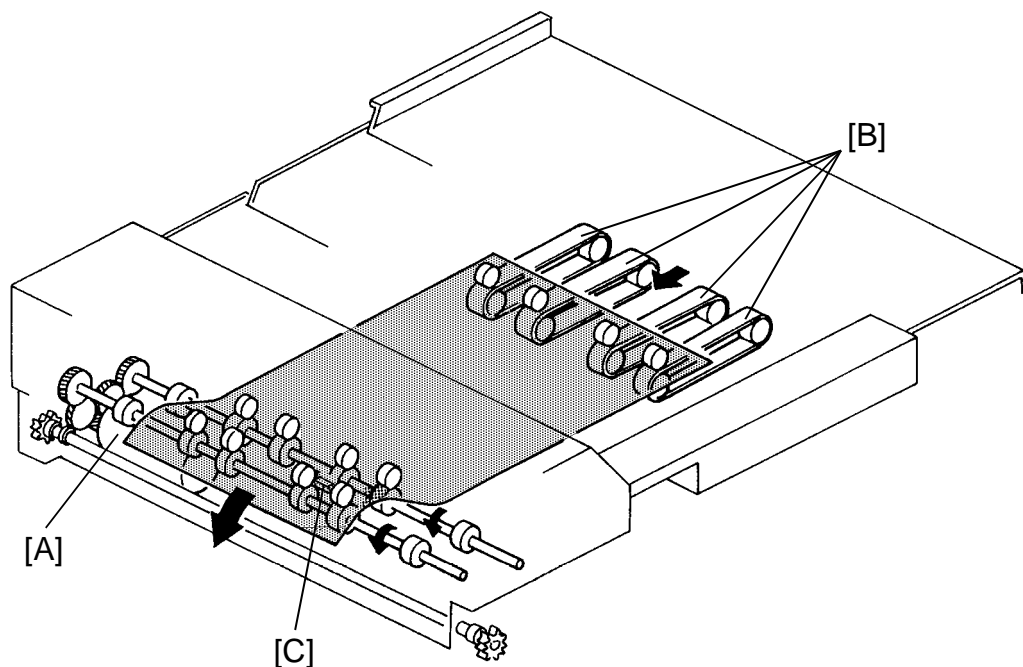

When the RDH receives the feed-out signal from the copier, the transport belt motor, the inverter motor, and the feed-out motor [A] start turning. Since the inverter solenoid is off at this time, the inverter pawls are positioned to direct the original to the exit relay belts [B]. The original is fed to the feed-out unit by the exit relay belts and then fed out of the RDH unit.

The feed-out motor drops to half of its normal speed 100 milliseconds after the original's leading edge passes the feed-out sensor [C]. It stays at half speed until 180 milliseconds after the original's trailing edge passes the feed-out sensor. This lower speed prevents uneven stacking of originals.

For B4/8 $\frac{1}{2}$ " x 14" and larger originals, the feed-out motor changes its speed 280 milliseconds after the original's leading edge passes the feed-out sensor.

11. ALTERNATE PAPER FEED

An alternate paper feed system can be used when the RDH and Finisher is installed.

This alternate paper feed system is a relatively efficient way to make two or more two-sided copies from two or more one-sided originals when the copier is equipped with an RDH.



When making two-sided copies, first of all, the even pages of the originals placed on the RDH are copied to the paper from the paper tray. They are then stored in the duplex tray. Then the originals are recirculated, the odd pages of the originals are copied to the sheets stored in the duplex tray. When making two or more sets of copies, the even pages of the recirculated originals are copied and they are stored in the duplex tray. The odd pages of the recirculated originals are copied to the sheets stored in the duplex tray. There are many benefits for this system.

Reduced transport time:

Before performing the two-sided copy process, the one-sided copy which has been stored in the duplex tray is fed onto a point near the registration rollers simultaneously with other copy processes, by which it can saving transport time.

– Operation –

(For example)

Two sets of two-sided copies are made from four one-sided originals.

- 1) When the start key is pressed the 4th and 2nd originals are scanned, then these copies are stacked in the duplex tray. The 3rd and 1st originals have only passed over the exposure glass [Fig 1].
- 2) The 4th original is scanned. The copy is stacked in the duplex tray. Soon after this, the bottom copy in the duplex tray is fed until its leading edge reaches the duplex exit sensor. This is in preparation for the reverse side copying [Fig 2].
- 3) The 3rd original is scanned. The copy which has been in the stand-by position is fed for copying the 3rd original and then fed out onto the copy tray [Fig 3].
- 4) The 2nd original is scanned and then it is stacked in the duplex tray. Soon after this, the bottom copy in the duplex tray is fed in preparation for the reverse side copying [Fig 4].
- 5) The 1st original is scanned. The copy which has been in the stand-by position is fed for copying the 1st original and then fed out onto the copy tray [Fig 5].
- 6) The 4th original is fed in the scanner and it is fed out from the RDH without exposing. After this, the bottom copy in the duplex tray is fed in preparation for the reverse side copying [Fig 6].
- 7) The 3rd original is scanned. The copy which has been in the stand-by position is fed for copying the 3rd original and then fed out onto the copy tray [Fig 6].
- 8) The 2nd original passes over the exposure glass. After this, the bottom copy in the duplex tray is fed in preparation for the reverse side copying [Fig 7].
- 9) The 1st original is scanned, the copy which has been in the stand-by position is fed for copying the 1st original and then fed out onto the copy tray [Fig 7].

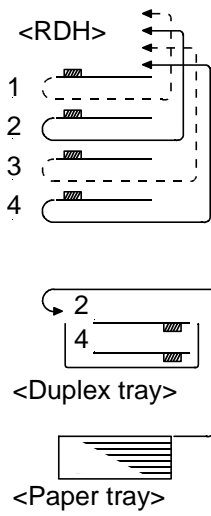

Fig 1

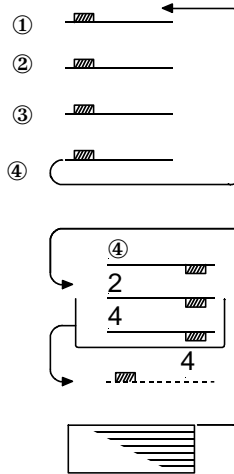

Fig 2

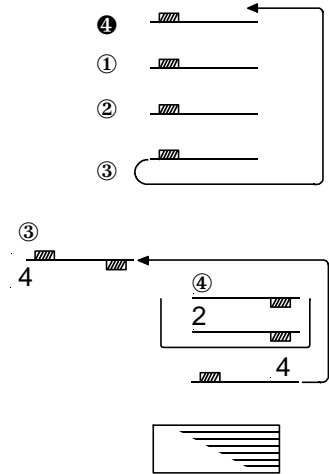

Fig 3

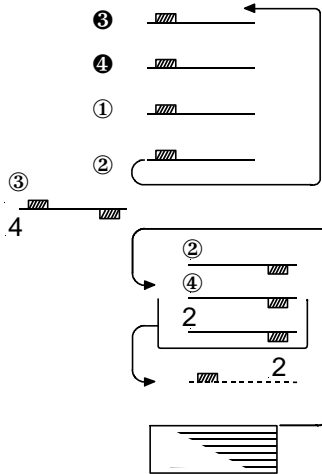

Fig 4

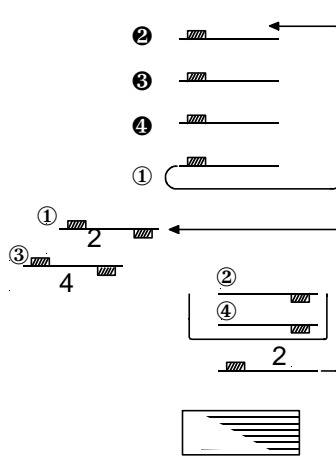

Fig 5

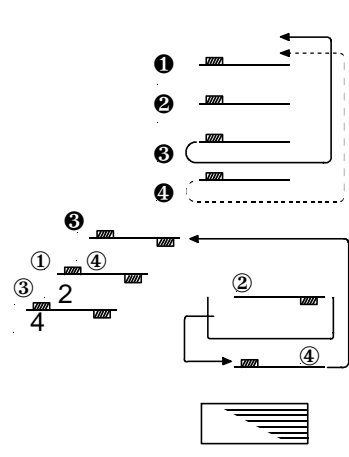

Fig 6

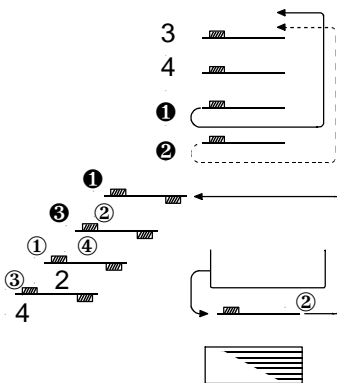

Fig 7

○: Recirculated
●: 3rd recirculated
- - - : Without exposing
(for RDH)

12. ORIGINAL MISFEED SENSING

The copier CPU lights the original misfeed indicator if the previous original remains on the exposure glass after manual copying and RDH feed is attempted. When the RDH is lifted and the previous original is removed, RDH copying is permitted.

12.1 One-sided original

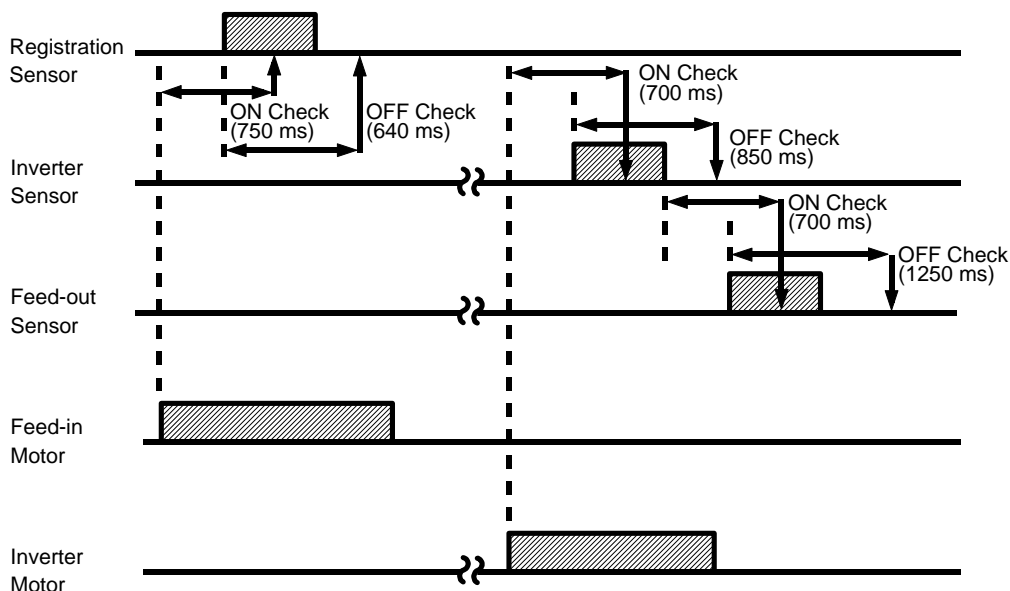

If the registration sensor is not actuated within 750 milliseconds after the feed-in motor starts turning, the Original Misfeed indicator lights (ON check). If the registration sensor does not turn off within 640 milliseconds, the CPU determines that there has been an original misfeed (OFF check).

If the inverter sensor is not actuated within 700 milliseconds after the inverter motor starts turning (ON check) or if the inverter sensor does not turn off within 850 milliseconds, the Original Misfeed indicator turns on.

If the feed-out sensor is not actuated within 700 milliseconds after the inverter sensor turns off (ON check), or if the feed-out sensor does not turn off within 1250 milliseconds, the Original Misfeed indicator lights (OFF check).

12.2 Two-sided original

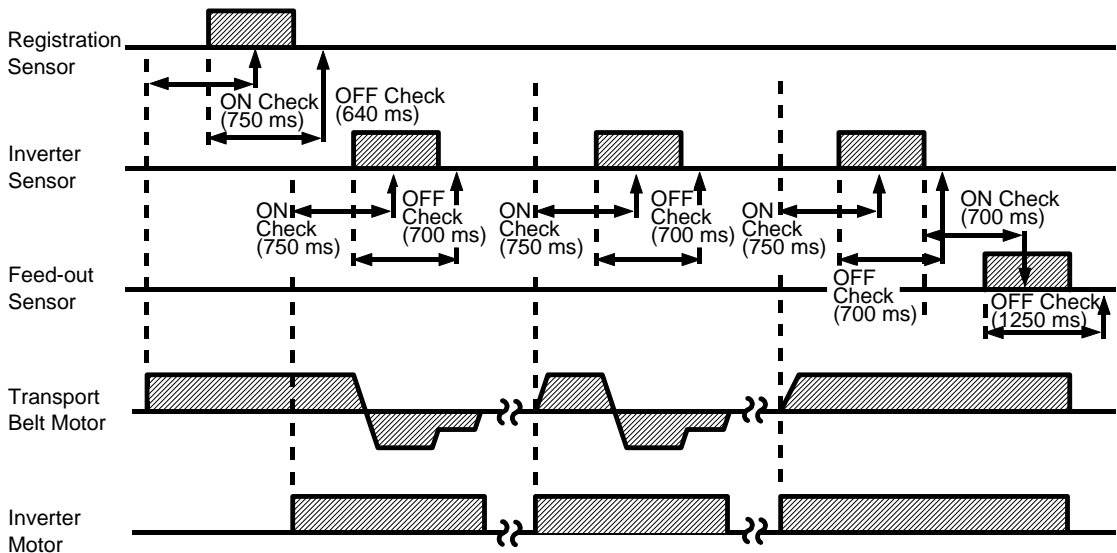

The ON/OFF check timing of the registration sensor is the same as in the one-sided original mode.

For original inversion, if the inverter sensor is not actuated within 750 milliseconds after the inverter motor turns on (ON check) or if the inverter sensor does not turn off within 700 milliseconds (OFF check), the Original Misfeed indicator lights.

During original feed-out, ON/OFF checks are performed at both the inverter sensor and the feed-out sensor at the same time as in the one-sided original mode.

13. INSTALLATION

13.1 ACCESSORY CHECK

Check the accessories in the box according to the following list:

Description	Q'ty
1. Installation Procedure.....	1
2. RDH Test Chart	1
3. Switch Actuator.....	1
4. Hinge Stopper.....	2
5. Shoulder Screw (-) – M5.....	2
6. Shoulder Screw (+) – M5.....	2
7. Shoulder Screw – M4	2
8. Philips Pan Head Screw – M4 x 6	2
9. NECR (for -17, -27 machines only)	1
10. Envelope - NECR (for -17 machine only)	1

13.2 INSTALLATION PROCEDURE

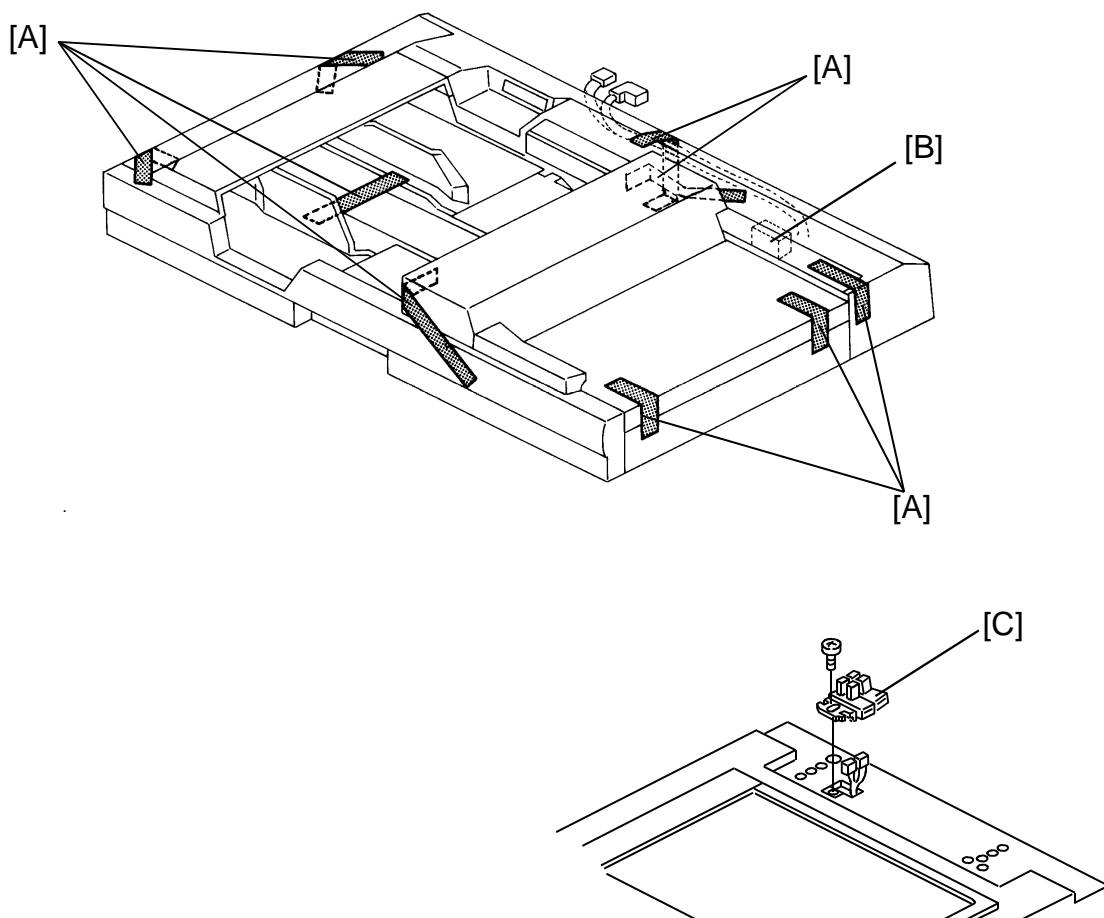

CAUTION: When installing the Recirculating Document Handler (RDH), make sure that the copier is unplugged.

1. Remove the tape strips [A] and the cushion [B] clamping the belt unit.
2. Remove the sensor [C] from the copier (1 screw).

NOTE: Sensor [C] is not installed to the copier when it is packed in its box.

Sensor [C] is an accessory of the platen cover (option).

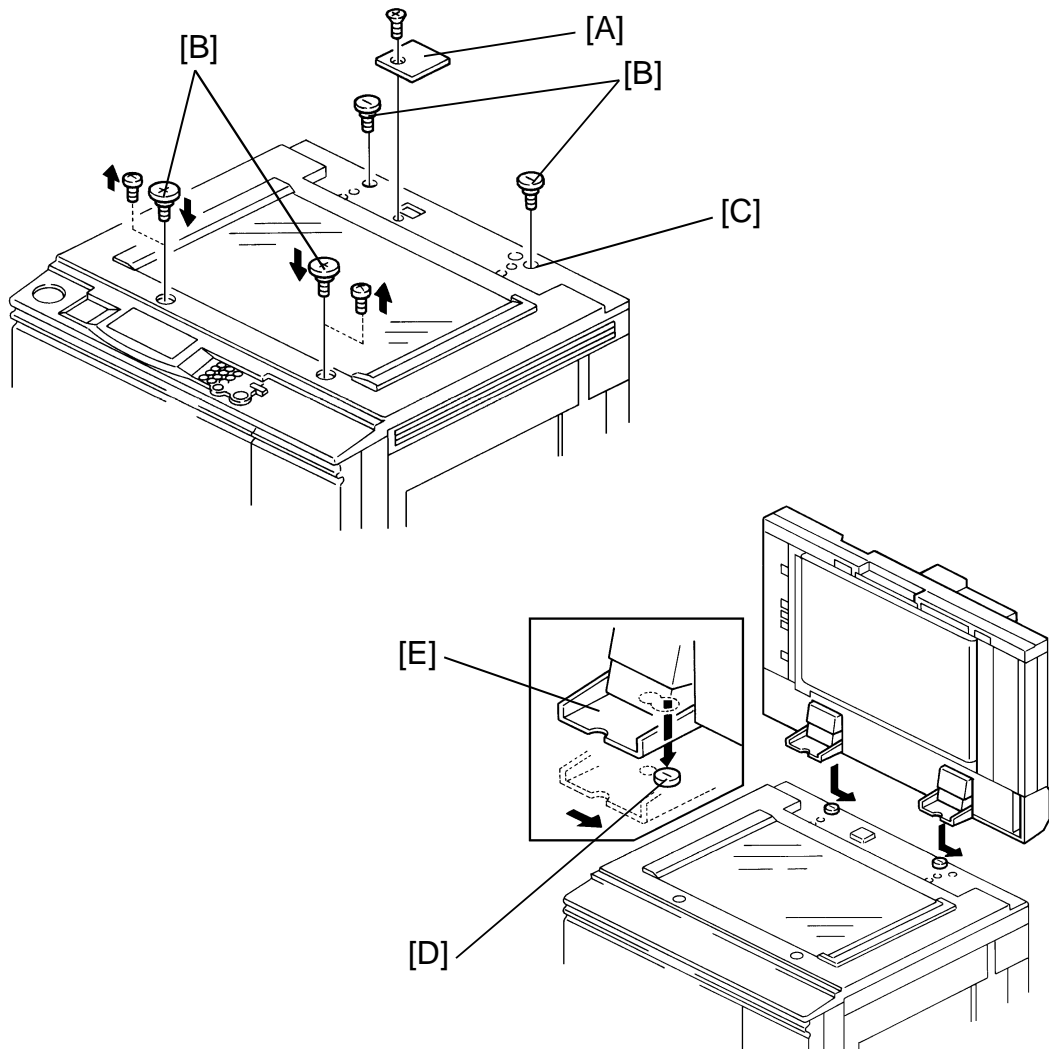

3. Install the cover [A] with a screw supplied as an accessories of the copier.
4. Install four stepped screws (front: M4, rear: M5 minus screw) [B] to hook the RDH.

NOTE: There is one screw hole available on the left side for one of the stepped screw. However there are two screw hole available on the right where the stepped screw is to be installed. Install the stepped screw into the outer screw hole [C] as shown in the illustration.

5. Mount the RDH to the two stepped screws [D] by aligning the holes in the RDH hinge [E] and the stepped screws, then slide the RDH to the right as shown.

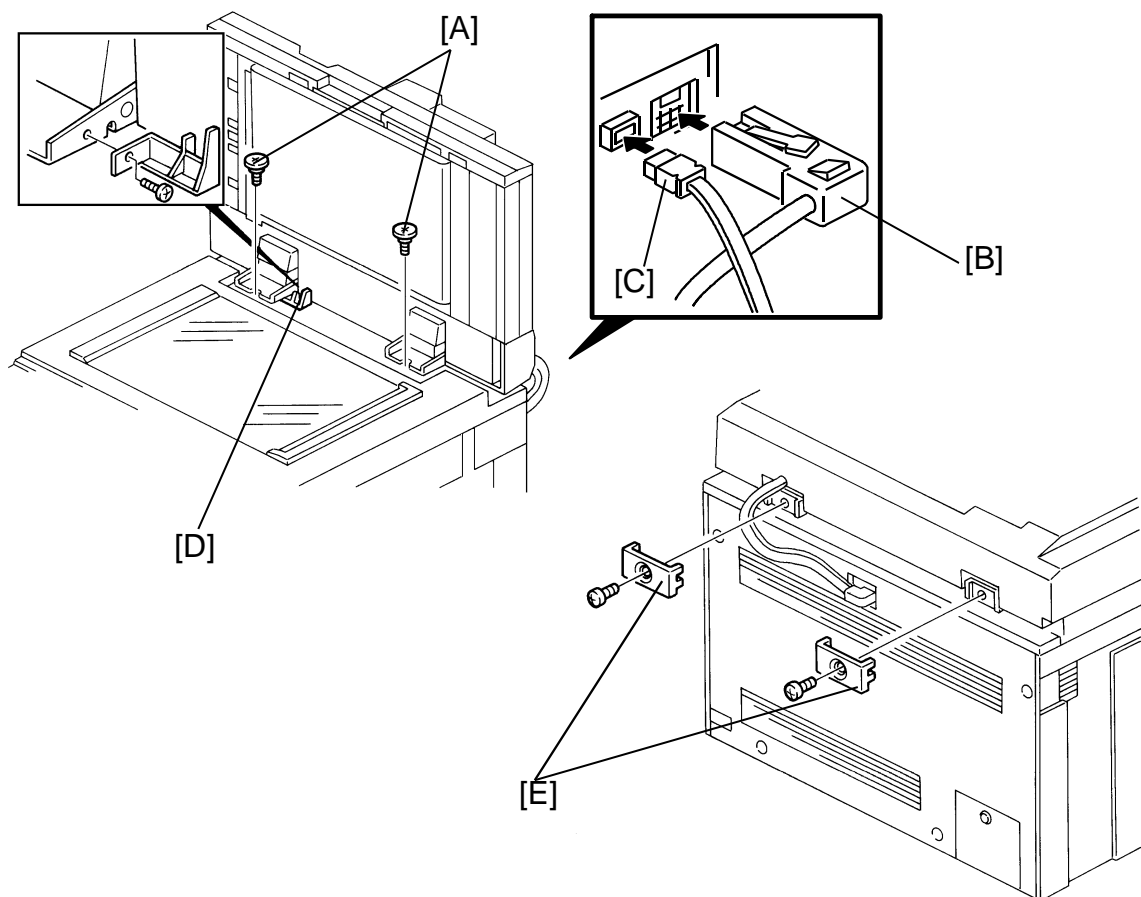

6. Secure the RDH to the copier with two plus (M5) stepped screws [A].
7. Remove a small cap on the upper rear cover of the copier then connect the connector [B] and the fiber optic cable connector [C].

CAUTION: Place the fiber optic cable [C] over the electrical cable [B] so as not to bend the fiber optic cable [C] while opening and closing the RDH.

8. Install the switch actuator [D] (1 screw).
9. Close the RDH then install the two angle stoppers [E].
10. Plug in the copier and turn on the main switch.

NOTE: The copier automatically recognizes that the RDH has been installed.
11. Make copies using the RDH and confirm the copy image.

14. SERVICE TABLE

14.1 TEST POINT TABLE

Number	Function
TP1	GND

14.2 FUSE TABLE (Main Board)

Number	Rated Current
F1	5A

14.3 LED TABLE

LED No.	ON Status
LED 1	Motor speed is too high.
LED 2	Motor speed is normal
LED 3	Motor speed is low

NOTE: While each motor is adjusted, if the motor speed is normal LED 2 lights, if the motor speed is too high LED 1 lights, if the motor speed is too low LED 3 lights.

14.4 DIP SWITCH TABLE

Factory Setting

DIP SW 2				DIP SW 1			
1	2	3	4	1	2	3	4
0	0	0	0	0	0	0	0

After performing the following tests, these DIP switches should be returned to the factory settings.

Motor Test

DIP SW 2				DIP SW 1				Description	Note
1	2	3	4	1	2	3	4		
1	1	0	1	1	0	0	0	Feed-in Motor	1
				0	1	0	0	Transport Belt Motor	
				0	0	1	0	Inverter Motor	
				0	0	0	1	Feed-out Motor	2

Note 1: When these DIP SW combinations are set. The motors start rotating. While SW 3 is held down. The motor rotates in the reverse direction.

Note 2: When these DIP SW combinations are set, the motors start rotating. While SW 3 is held down, the motor rotates slowly.

Paper Feed

DIP SW 2				DIP SW 1				Description
1	2	3	4	1	2	3	4	
0	1	0	1	0	0	0	0	Feeds a sheet of paper (Scale Registration)
				0	1	0	0	Feeds a sheet of paper (Timing Registration)

Note: With these DIP SW combinations, press SW 3 to feed a sheet of paper. Press SW 3 again to reverse the paper feed direction, then press SW 3 to feed out the paper sheet.

Clutch and Solenoid Test

DIP SW 2				DIP SW 1				Description
1	2	3	4	1	2	3	4	
0	0	1	1	1	0	0	0	Push Plate Solenoid
				0	1	0	0	Feed Clutch
				0	0	1	0	Inverter Solenoid
				0	0	0	1	Original Gate Solenoid

Note: Press SW 3 to energize the clutches and solenoids.

Free Run Mode (With paper)

DIP SW 2				DIP SW 1				Description	Note
1	2	3	4	1	2	3	4		
1	0	0	1	0	0	0	0	Single Operation (Scale Registration, Single Side)	1
				1	0	0	0	Single Operation (Scale Registration, Double Side)	
				0	1	0	0	Single Operation (Timing Registration, Single Side)	
				*	*	0	1	Repeat Operation (Up to 30 sets)	
				*	*	1	1	Repeat Operation (Limitless)	

Note 1: With these DIP SW combinations, press SW 3 to start feeding sheets from a paper stack in and out. Each sheet is fed once.

Note 2: With these DIP SW combinations, press SW 3 to feed paper in and out continuously. (The same stack of sheets is fed in and out repeatedly.)

Free Run (Without paper)

DIP SW 2				DIP SW 1				Description
1	2	3	4	1	2	3	4	
1	1	1	0	0	0	0	0	Free Run

Note: With this DIP SW combination, press SW 3 to start RDH operation without paper. Press SW 3 again to stop.

15. REPLACEMENTS AND ADJUSTMENTS

15.1 TRANSPORT BELT REPLACEMENT

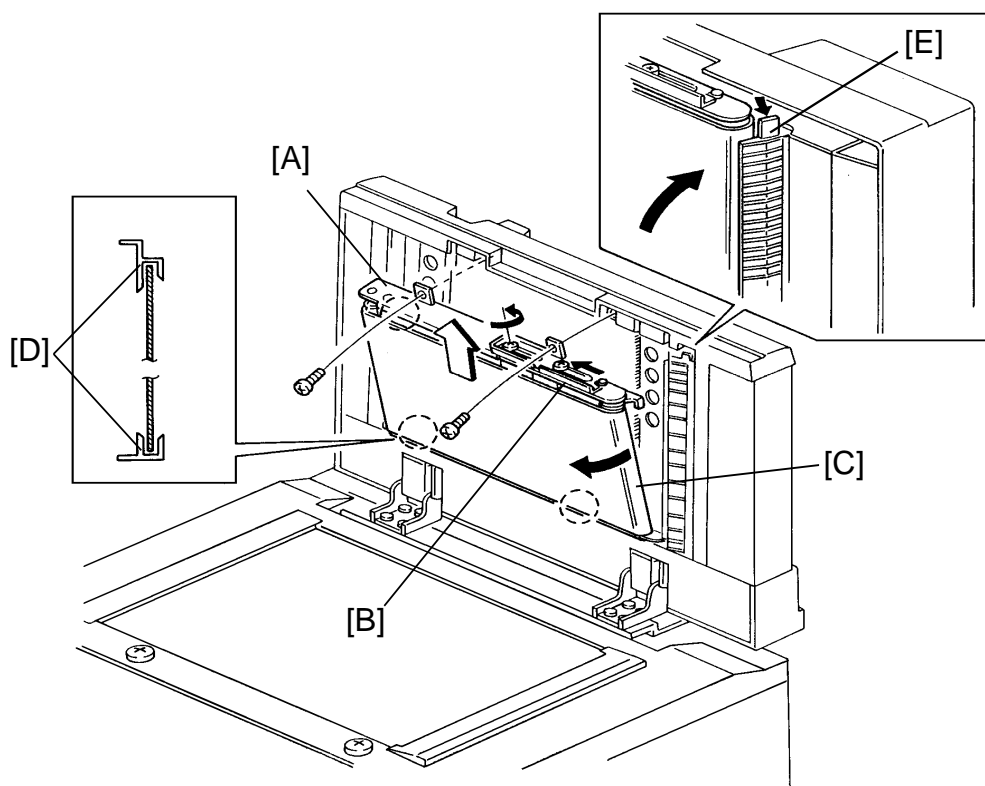

1. Turn off the copier main switch and lift the RDH unit.
2. Open the transport belt unit [A] (2 screws).
3. Slide the belt tension plate [B] to the left (1 screw), then lower the belt tension unit [C].
4. Replace the transport belt.

NOTE: The RDH belt has to be installed in the notch as shown [D]. The feed out unit [E] has to be opened when the transport belt unit is reinstalled.

15.2 PAPER FEED ROLLER REMOVAL

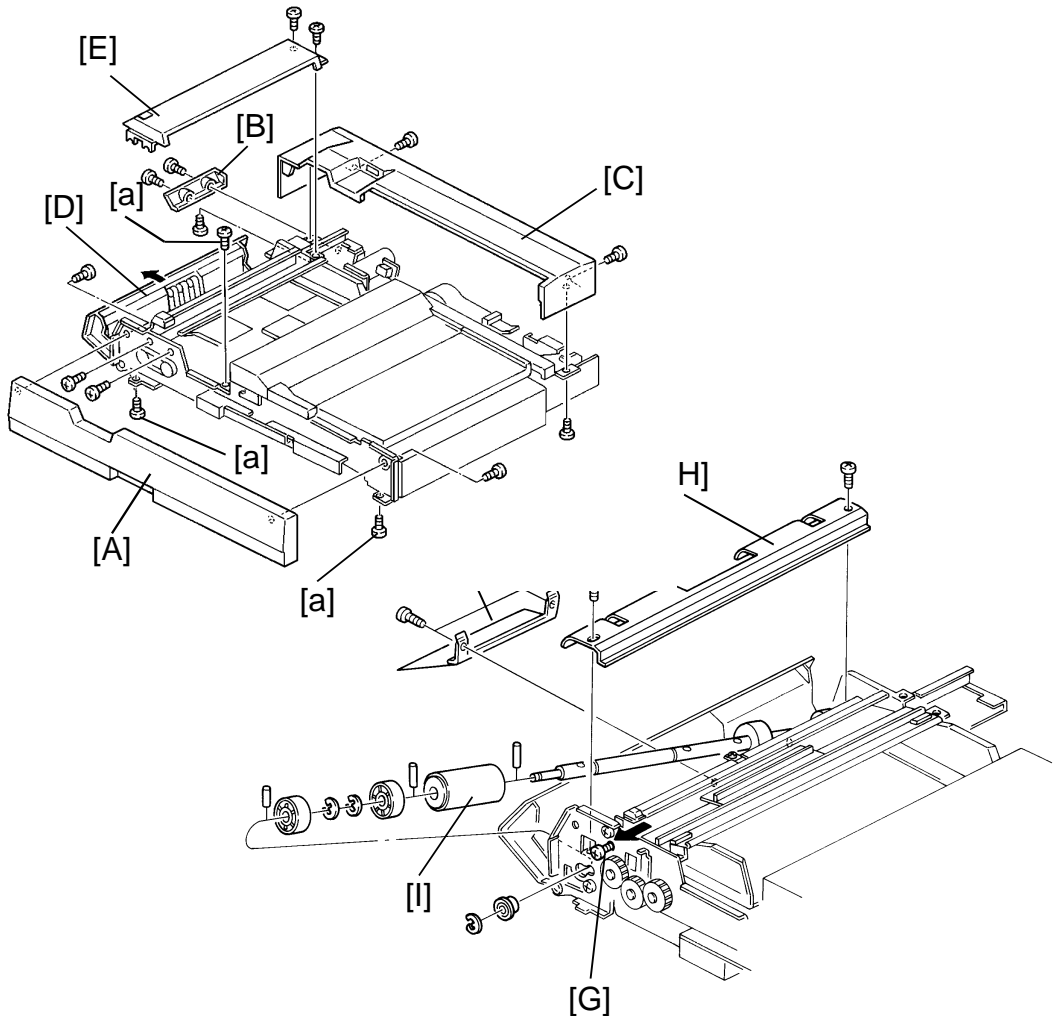

1. Turn off the copier main switch, then remove the RDH front cover [A] (remove 2 screws, loosen 3 screws [a]) and the lower rear cover [B] (2 screws).
2. Remove the rear cover [C] (4 screws).
3. Open the feed-in unit [D].
4. Remove the feed-in unit cover [E] (4 screws) and the paper guide mylar [F] (2 screws).
5. Loosen the feed-in unit release button holder pins [G], then slide the holder to the front and remove the paper feed guide plate [H] (2 screws).
6. Remove the paper feed roller [I] (3 E-rings, 1 bearing, 2 pins, and 2 pull-out rollers).

NOTE: Be careful not to lose the pins.

15.3 FRICTION BELT REPLACEMENT

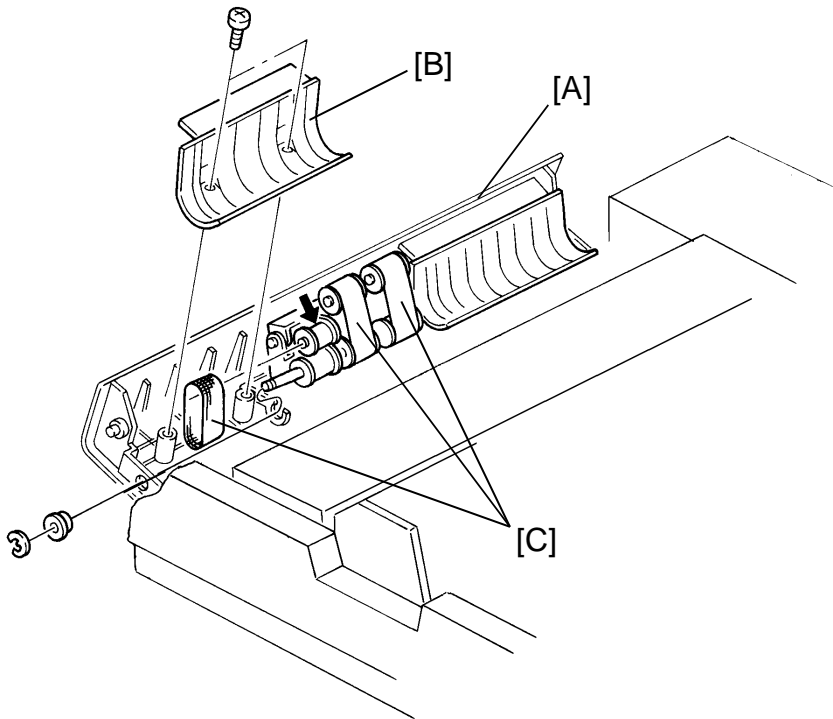

1. Turn off the copier main switch, then open the paper feed unit [A].
2. Remove the paper guide plate [B] (2 screws).
3. Replace the 3 friction belts [C] (1 E-ring and 1 busing).

15.4 PAPER EXIT TRANSPORT BELT REMOVAL

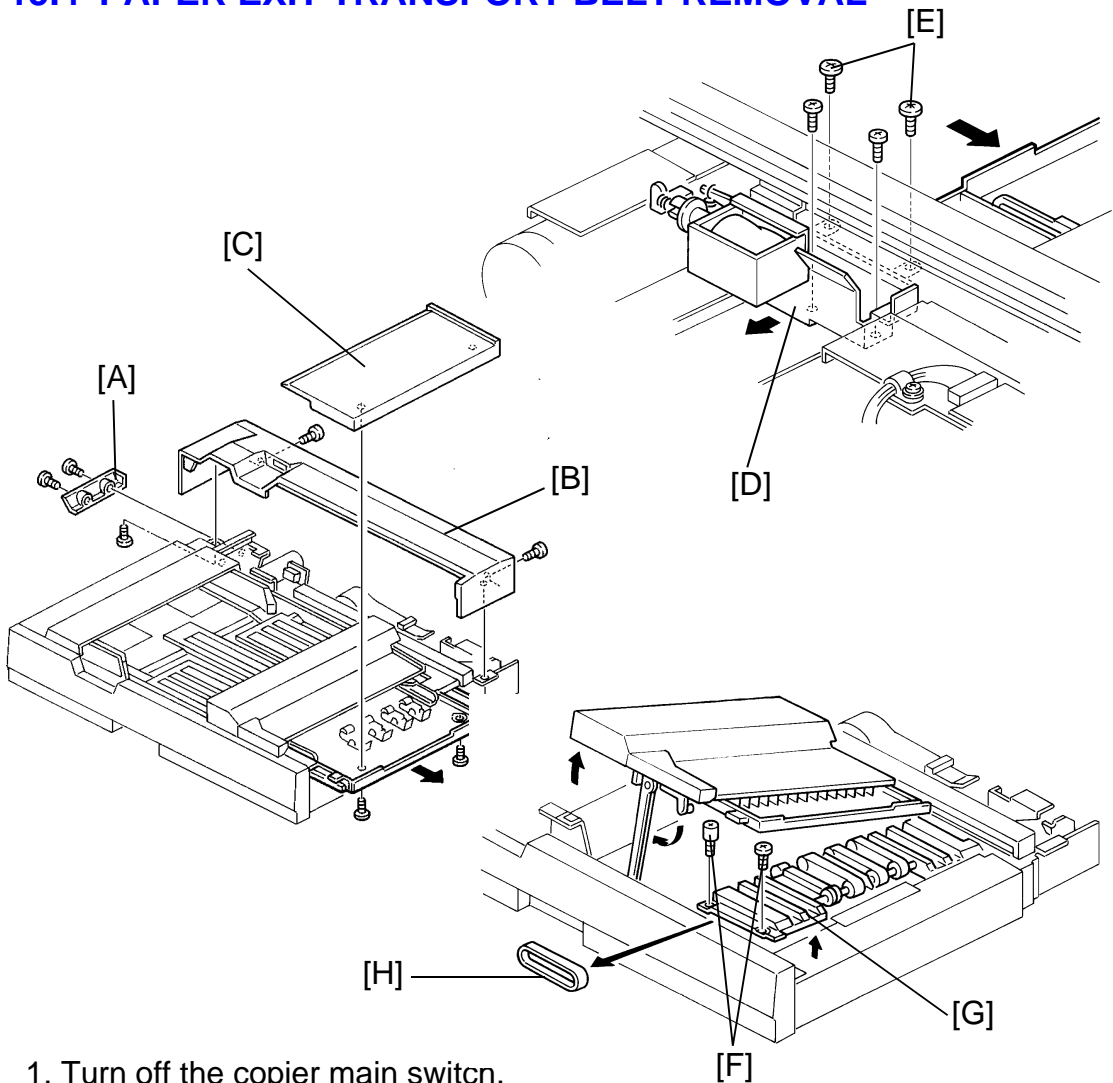

1. Turn off the copier main switch.
2. Remove the lower rear cover [A], rear cover [B] and the right side cover [C] (2 screws).
3. Remove the inverter solenoid bracket [D] (2 screws).
4. Slide the paper exit unit all the way to the left.
5. Remove the 2 screws for the transport unit [E] , and open the exit unit. Then remove the other 2 screws [F].
6. Carefully lift the front end of the transport unit [G], then remove the 4 paper exit transport belts [H].

NOTE: Reinstall the inverter solenoid bracket, after sliding the paper exit unit all the way to the right.

15.5 RDH MAIN CONTROL BOARD REMOVAL

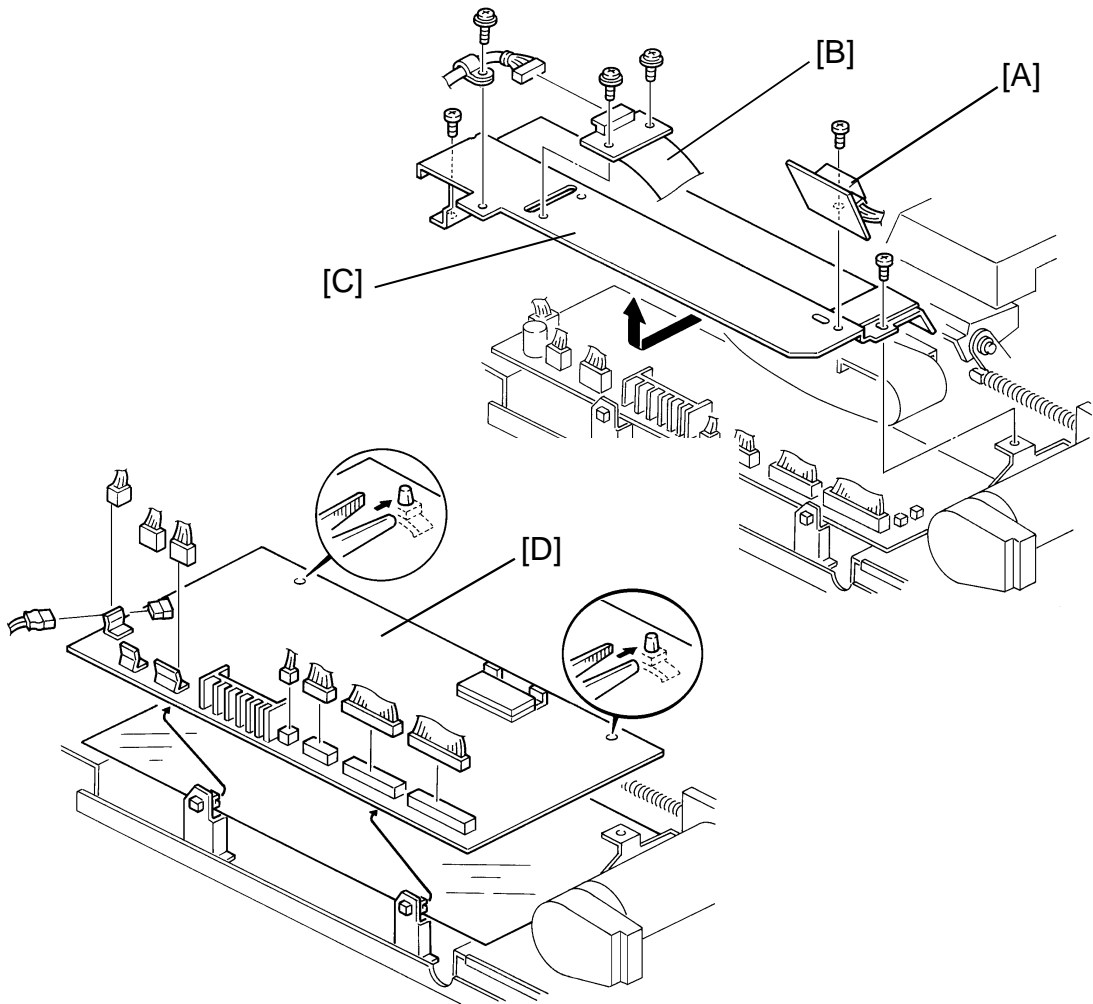

1. Turn off the copier main switch, then remove the rear cover.
2. Disconnect all connectors for the main control board and for the flexible cable (8 connectors, 1 optics cable, 1 harness clamp).
3. Remove the LED bracket [A] (1 screw) and the flexible cable [B] (2 screws).
4. Remove the main board cover [C] (2 screws).
5. Remove the main control board [D].

NOTE: After replacing the main control board, perform the leading edge registration and the motor speed adjustments.

15.6 RDH LEADING EDGE REGISTRATION ADJUSTMENT

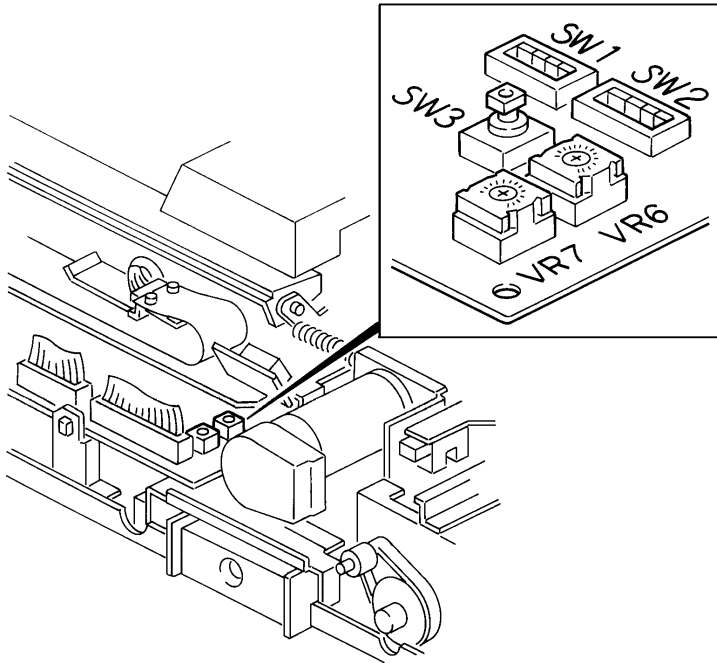

NOTE: Before confirming the original registration, make sure that the main frame registration is within specifications.

1. Confirm the original front side registration as follows:
 - 1) Make a copy of the test chart in platen mode (A4/81/2" x 11", sideways).
 - 2) Make a copy of the test chart in RDH mode.
 - 3) Compare the registration of the copy in platen mode with that in RDH mode, and confirm that there is no more than a 1.0 mm difference.
 - 4) If the difference is more than 1.0 mm, adjust the registration by using the copier's SP mode (SP Adjustment – PAGE 6).
 - 5) Install the RDH rear cover.

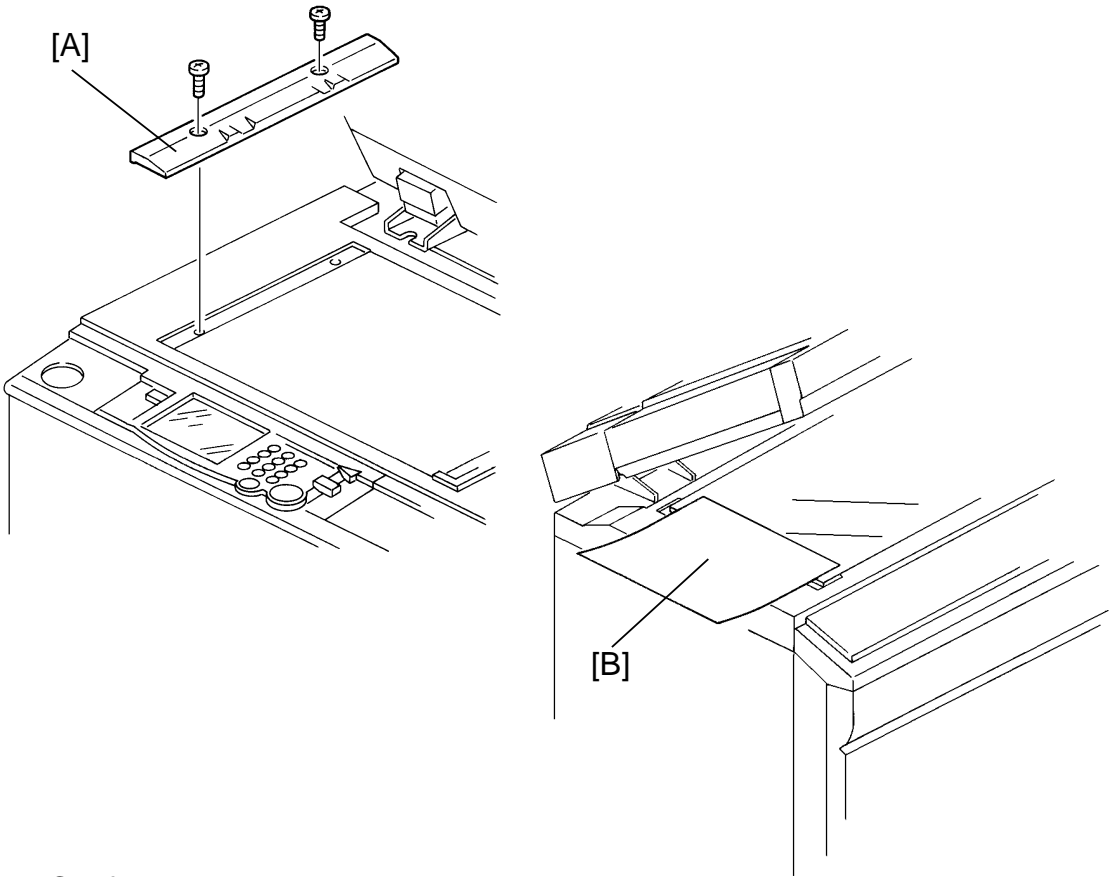

2. Confirm the original reverse side registration as follows.

- 1) Make a copy of the test charts 2nd side in platen mode (A4/8 1/2" x 11", sideways).
- 2) Make a copy of the test chart in RDH 2-sided mode.
- 3) Compare the registration of the copy in platen mode with that in RDH 2-sided mode, and confirm that there is no more than a 2.0 mm difference.
- 4) If the difference is more than 2.0 mm, remove the left scale [A] (2 screws), then set a sheet of A4/8 1/2" x 11" sideways paper [B] on the exposure glass edge as shown.

NOTE: Without the left scale, the original jams when it strikes the exposure glass edge. This sheet of paper prevents that.

5) Set DIP SW 1 and 2 on the main PCB as follows:

DIP SW 2				DIP SW 1			
1	2	3	4	1	2	3	4
0	1	0	1	0	1	0	0

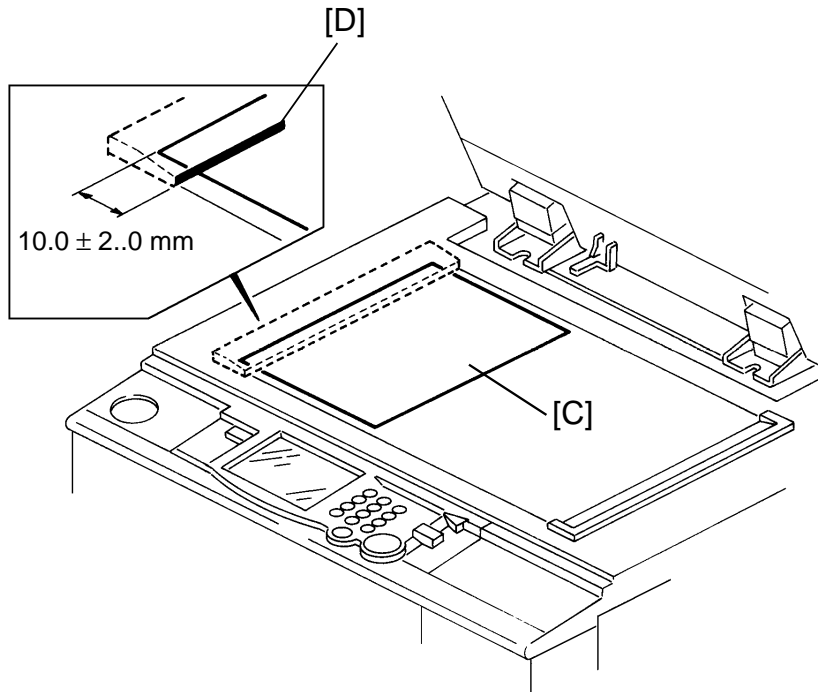

- 6) Set a test chart on the RDH, then press SW 3 to feed the test chart through the RDH.
 - 7) When the test chart stops on the exposure glass, gently pull off the sheet of paper set in step 4), then press SW 3 again to feed the test chart in the reverse direction.
 - 8) Open the RDH slowly so that the test chart [C] does not move from the stop position.
 - 9) Confirm that the test chart has stopped at the correct position, 10 ± 2.0 mm from the scale edge (0 position) [D].
 - 10) If the test chart did not stop at the correct position, adjust the registration by using the copier's SP mode (SP Adjustment – PAGE 6).
3. Turn all DIP SW's off and turn off the main switch, then reassemble the machine.
 4. Check the operation of the RDH.

15.7 MOTOR SPEED CHECK & ADJUSTMENT

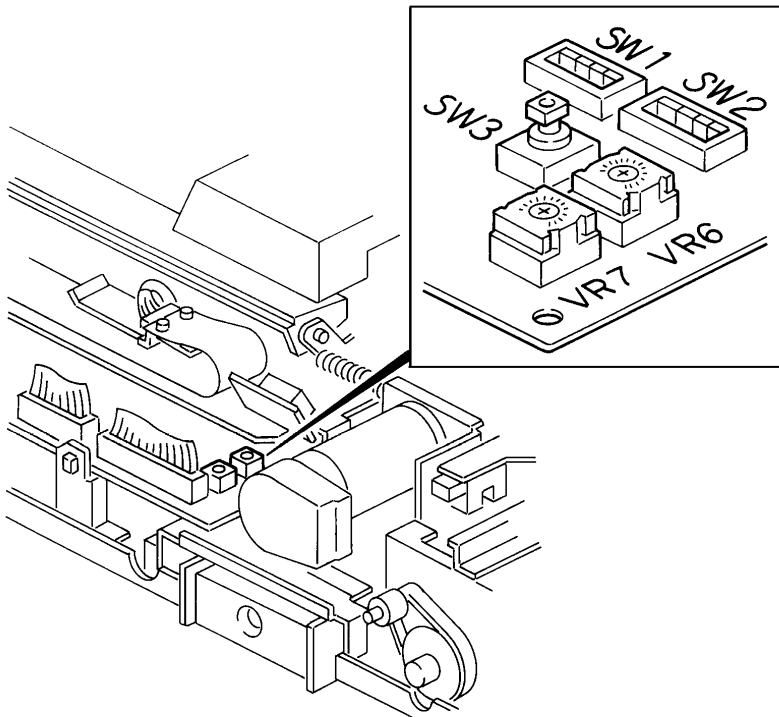

1. Remove the RDH rear cover (4 screws), and set DIP SW 1 and 2 as follows:

DPS 2				DIP SW				Description	DIP SW Combination
				DPS 1					
1	2	3	4	1	2	3	4		
1	1	0	1	1	0	0	0	Feed-in Motor	1
				0	1	0	0	Transport Belt Motor	2
				0	0	1	0	Inverter Motor	3
				0	0	0	1	Feed-out Motor	4

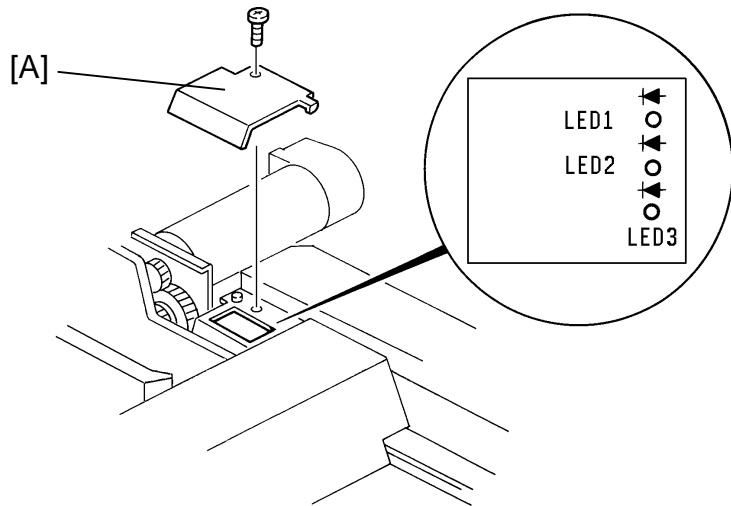
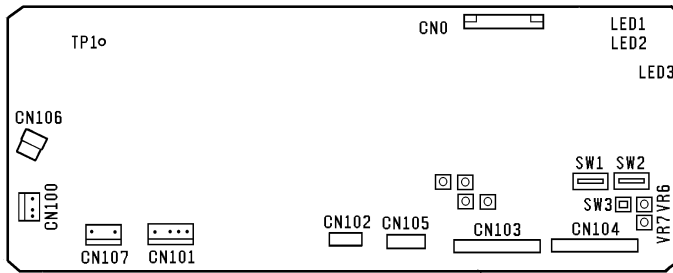

2. Close the RDH and remove the LED cover [A] (1 screw).

NOTE: For the DIP SW combinations, refer to the table on the previous page.

3. Set DIP SW 1 combination #1. The paper feed motor starts turning. Turn VR 3 until LED 2 lights.

4. Set DIP SW 1 combination #1. The paper feed motor reverses direction while SW 3 is pressed (ON). Turn VR 2 until LED 2 lights.

5. Set DIP SW 1 combination #2. The transport belt motor starts. Turn VR 1 until LED 2 lights.

6. Set DIP SW 1 combination #3. The inverter motor starts turning. Turn VR 4 until LED 2 lights.

7. Set DIP SW 1 combination #4. The feed-out motor starts turning. Turn VR 5 until LED 2 lights.

8. Check the operation of the RDH.

9. Turn all DIP SW's off.

10. Reassemble the machine.